

PRODUCT DATA SHEET

BIANCO - FC150T • 802807



BRAND

BIANCO
PUMPZ

PRODUCT DETAILS

The BIANCO FC150T is a robust cast iron, single stage, horizontal end suction centrifugal pump.

Manufactured using high quality materials and components BIANCO FC Series are quiet and reliable offering 'best in class' high performance operation.

APPLICATIONS

- Ideal for use in agriculture, horticulture or other industrial services
- Wash-down, tank filling, HVAC, circulation, fire suppression, pressure boosting.

FEATURES

- 400V Three phase TEFC motor with in-built auto reset thermal overload to prevent pump from damage
- Excellent motor and hydraulic efficiency
- Electrochemical **cataphoresis** treatment applied to the pump body for enhanced corrosion resistance

To protect the pump from excessive cycling and to isolate from the effects of water hammer, adding a pressure tank to the system is highly recommended

TECHNICAL DATA

RATED POWER (P2)	1.5kW (2.0hp)
MAX. FLOW [LPM]	500 LPM
MAX. HEAD [M]	22.5m
MAX. PRESSURE RATING	8 bar
FLUID TEMP RANGE	4 - 60 deg C
MAX. AMBIENT TEMP	40 deg C
MOTOR RATING	Continuous
MOTOR INSULATION	Class F
PUMP BODY	Cast Iron HT200
MOTOR SHAFT AND IMPELLER	304 grade stainless steel
MECHANICAL SEAL	Carbon / Ceramic
O RINGS	Nitrile

RATED VOLTAGE (V)	3 ph 380V (-6%) to 415V (+6%) 50 hz
RATED CURRENT (A)	3.3A
RATED SPEED (RPM)	2800 - 2 pole
MOTOR TYPE	Asynchronous, TEFC
IP RATING	I.P. 44
SUCTION CONNECTION	2" BSPF and DIN Flange
DISCHARGE CONNECTION	2" BSPF and DIN Flange
AUTOMATIC OPERATION	No - bare pump only
MOTOR PROTECTION	Auto re-setting thermal overload
CARTON DIMENSIONS	414mm L x 230mm W x 300mm H
GROSS WEIGHT (KG)	24.0kg

CURVE

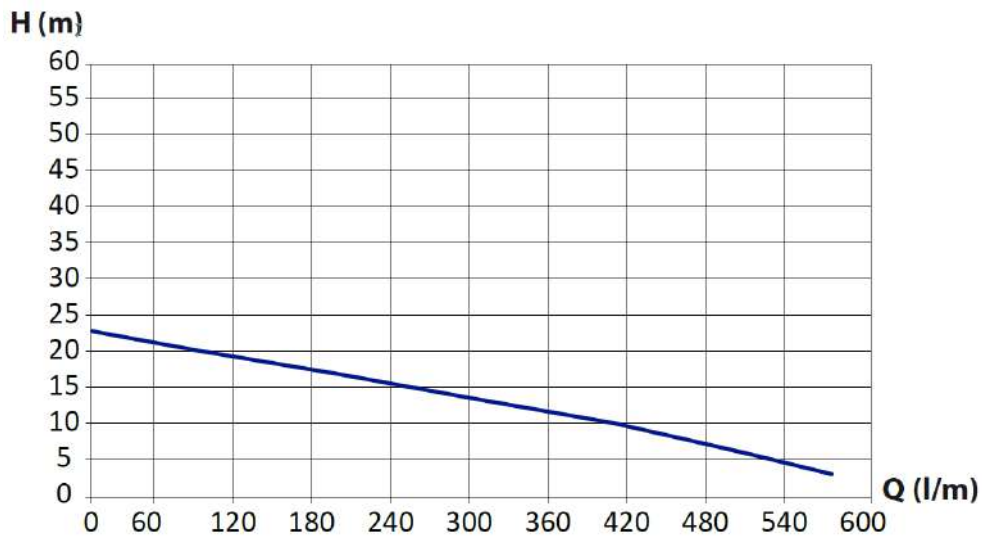

BIA-FC150M / T

DIMENSIONS

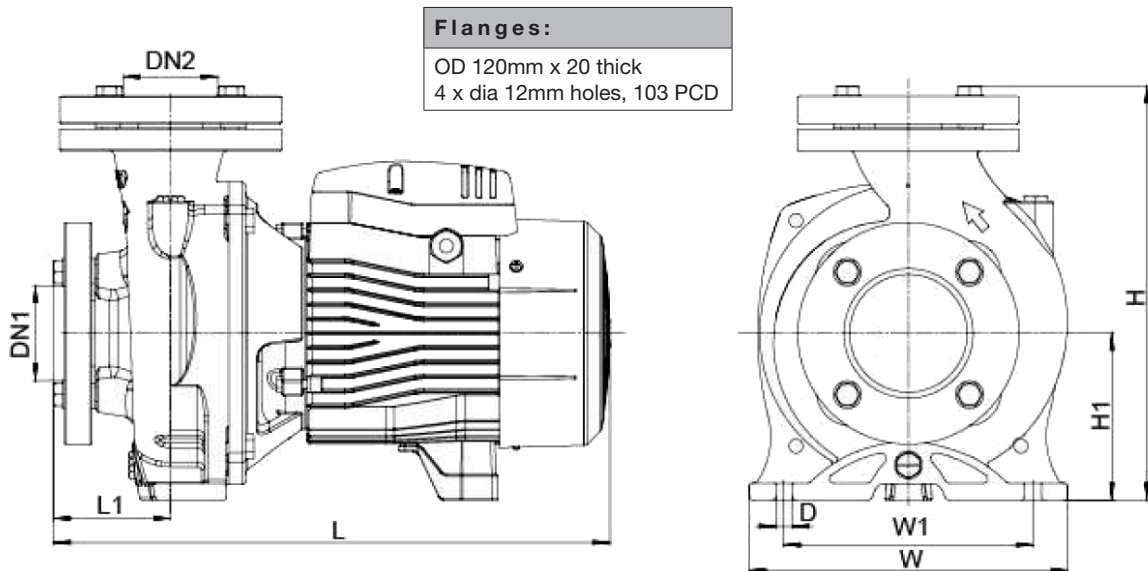

MODEL	L	W	H	L1	W1	H1	Bolt Hole Ø	DN1	DN2
BIA - FC150T	385mm	206mm	270mm	64.5mm	166mm	112mm	10mm	2" BSPF In	2" BSPF Out

WARRANTY / CERTIFICATIONS

